

# FRESA DE TOPO RETO DE METAL DURO - 63HRC

## 4 CORTES - STANDARD

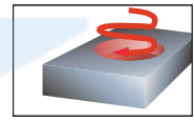
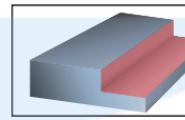
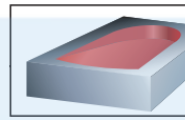
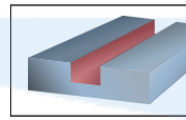
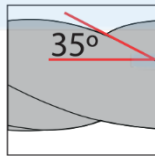
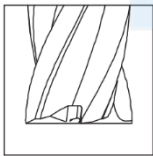
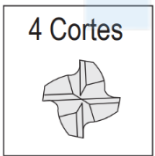
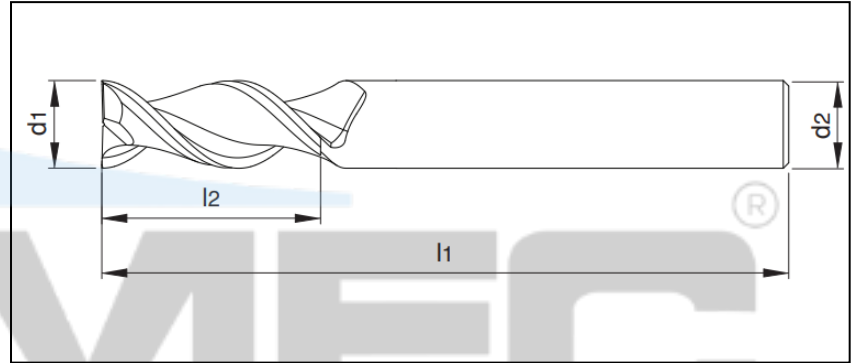
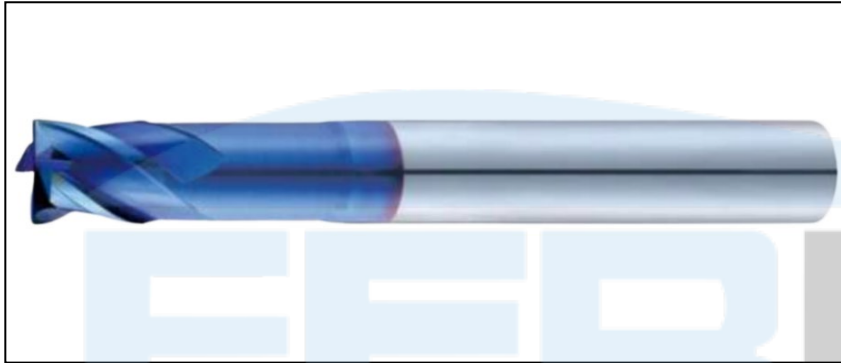

Código	d1	l2	l1	d2
F MD D 1MM 4C H4 C/C 63HRC	1.0	1.5	50	4
F MD D 1MM 4C H6 C/C 63HRC	1.0	1.5	50	6
F MD D 1.5MM 4C H4 C/C 63HRC	1,5	2.2	50	4
F MD D 2MM 4C H4 C/C 63HRC	2.0	3	50	4
F MD D 2MM 4C H6 C/C 63HRC	2.0	3	50	6
F MD D 2.5MM 4C H4 C/C 63HRC	2.5	3.5	50	4
F MD D 3MM 4C C/C 63HRC	3.0	4	50	3
F MD D 3MM 4C H4 C/C 63HRC	3.0	4	50	4
F MD D 3MM 4C H6 C/C 63HRC	3.0	4	50	6
F MD D 4MM 4C C/C 63HRC	4.0	5	50	4
F MD D 4MM 4C H6 C/C 63HRC	4.0	5	50	6
F MD D 5MM 4C C/C 63HRC	5.0	6	50	5
F MD D 6MM 4C C/C 63HRC	6.0	7	50	6
F MD D 8MM 4C C/C 63HRC	8.0	9	60	8
F MD D 10MM 4C C/C 63HRC	10.0	11	75	10
F MD D 12MM 4C C/C 63HRC	12.0	13	75	12